

## 90 DAY LIMITED WARRANTY

Winegard Company warrants this Winegard product against any defects in materials or workmanship within 90 (ninety) days from date of purchase. No warranty claim will be honored unless at the time the claim is made, you present proof of purchase to an authorized Winegard dealer (if unknown, please contact Winegard Company, 3000 Kirkwood Street, Burlington, IA 52601-2000, Telephone 800-288-8094).

Winegard Company (at its option) will either repair or replace the defective product at no charge to you. This warranty covers parts, but does not cover any costs incurred in removal, shipping or reinstallation of the product. This limited warranty does not apply if the product is damaged, deteriorates, malfunctions or fails from: misuse, improper installation, abuse, neglect, accident, tampering, modification of the product as originally manufactured by Winegard, usage not in accordance with product instructions or acts of nature such as damage caused by wind, lightning, ice or corrosive environments such as salt spray and acid rain.

The 90 Day Warranty is provided on the condition that the equipment is properly delivered with all handling and freight charges prepaid to your Winegard dealer for return to our factory for repair or replacement. Winegard dealers will arrange for the replacement or repair and return to you without charge the product which failed due to defective material or workmanship.

WINEGARD COMPANY WILL NOT ASSUME ANY LIABILITIES FOR ANY OTHER WARRANTIES, EXPRESS OR IMPLIED, MADE BY ANY OTHER PERSON.

ALL OTHER WARRANTIES WHETHER EXPRESS, IMPLIED OR STATUTORY INCLUDING WARRANTIES OF FITNESS FOR A PARTICULAR PURPOSE AND MERCHANTABILITY ARE LIMITED TO THE 90-DAY PERIOD OF THIS WARRANTY.

The foregoing shall be the sole and exclusive remedy of any person, whether in contract, tort or otherwise, and Winegard shall not be liable for incidental or consequential damage or commercial loss, or from any other loss or damage except as set forth above.

Some states do not allow limitations on how long an implied warranty lasts, or the exclusion of limitation of incidental or consequential damages, so the above limitations or exclusions may not apply to you.

This warranty gives you specific legal rights and you may also have other rights which vary from state to state.

Rev. 2/08

## HOW TO PROVIDE LIGHTNING PROTECTION FOR TV ANTENNA AND SET

**Step 1.** Mount the lightning arrestor or 75 ohm coaxial grounding block as close as possible to where the 75 ohm coaxial cable download enters the house.

**Step 2.** The ground wires for both the mast and the download should be copper or aluminum wire, number eight (8) or larger.

**Step 3.** The download wire from the antenna to the lightning arrestor and the mast ground wire should be secured to the house, spaced from four (4) to six (6) feet apart.

**NOTE:** In the case of a "ground up" antenna installation, it may not be necessary to ground the mast if the mast extends four or more feet into the earth. Consult a TV serviceman for the proper depth in your location.

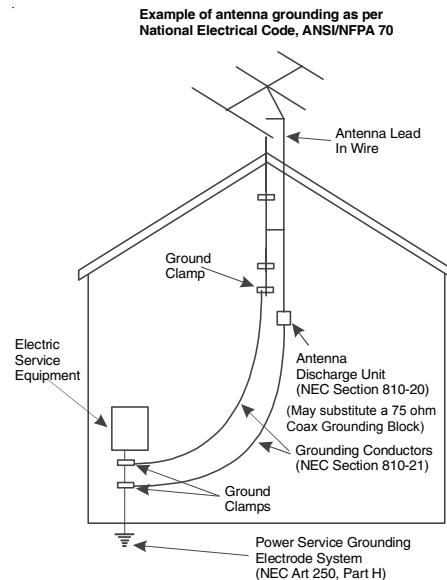

Printed in U.S.A. © 2004, 2006 Winegard Company Rev4 12-13 2451966

# WINEGARD®

## SENSAR® TV ANTENNA

Amplified Model GS-2200

Non-amplified Model GS-1100

Made in U.S.A.

U.S. Patent No. D500,496

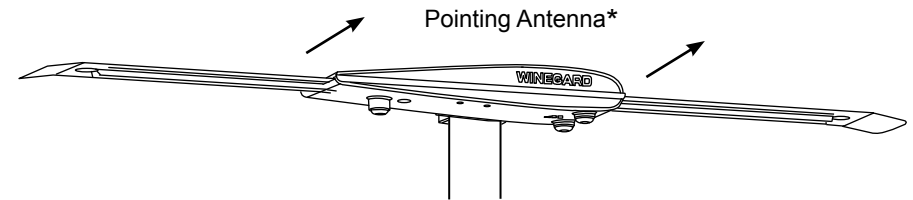

\*Point the front of the antenna (with Winegard logo) at broadcast towers of stations you want to receive.

Register your product at  
[winegard.com/myantenna](http://winegard.com/myantenna)

**WARNING: INSTALLATION OF ANTENNAS NEAR POWER LINES IS DANGEROUS. FOR YOUR SAFETY, FOLLOW THE INSTALLATION INSTRUCTIONS.**

**WARNING: TO PREVENT FIRE OR SHOCK HAZARD, DO NOT EXPOSE POWER SUPPLY TO RAIN OR MOISTURE.**

**NOTE: Any alteration or modification to product or any other use of the parts other than their intended use, voids the warranty.**

WINEGARD CO., 3000 KIRKWOOD STREET, BURLINGTON, IA 52601-2000

## WARNING:

**INSTALLATION OF ANTENNAS NEAR POWER LINES IS DANGEROUS. FOR YOUR SAFETY, FOLLOW THE INSTALLATION INSTRUCTIONS.**

## INSTALLATION

This SENSAR antenna may be installed inside or outside on any mast or pole. **DO NOT MOUNT OVER CHIMNEY OPENING.**

**STEP 1.** Make sure "W" opening is on bottom side of antenna head, foot embossing points down. Slide metal mounting bracket up into back bracket on antenna and attach with pins and E-clips. See Figure 1.

**STEP 2.** Insert "U" bolt thru mast clamp and mast bracket and start hex nuts onto "U" bolt. See Figure 1.

**STEP 3.** Slide mast thru "U" bolt and tighten hex nuts with 7/16" wrench.

### Model GS-1100 (Non-amplified Models ONLY)

#### Attaching Download Cable

**STEP 4.** Attach download coax cable to F-jack on back of antenna head and tighten securely. (Figure 3). Tape download to mast and run coax cable to TV. Point the front of the antenna (with Winegard logo) at broadcast towers of stations you want to receive.

**STEP 5.** Attach "F" connector to download and connect to "F" jack on TV.

Figure 1

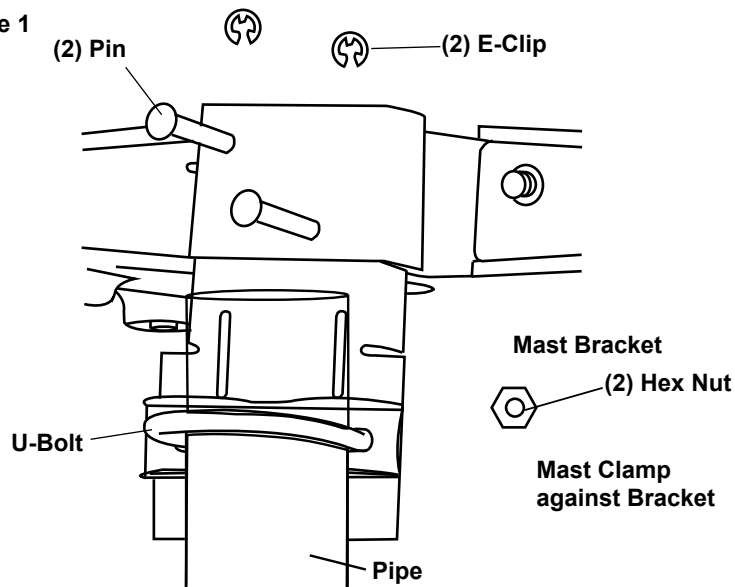
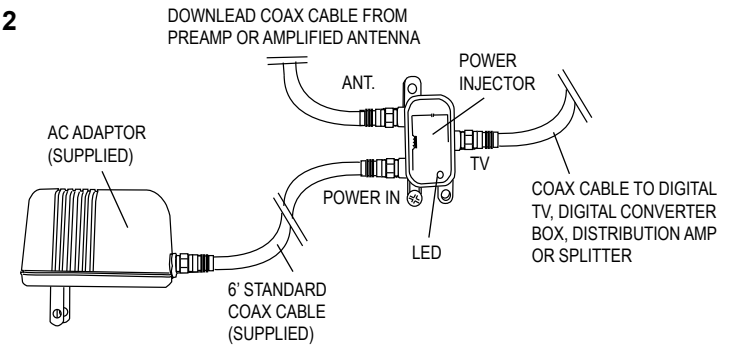

Figure 2



### Models GS-2200 (Amplified Models ONLY)

#### Attaching Download Coax Cable

If using the power supply, follow these steps.

**STEP 4.** Attach "F" connector on download coax cable to the power injector jack marked "ANTENNA". Point the front of the antenna (with Winegard logo) at broadcast towers of stations you want to receive

**STEP 5.** Attach "F" connector on coax cable from DTV, Digital Converter box, Distribution Amplifier, or splitter system to jack on Power Injector marked TV.

**STEP 6.** Connect one "F" connector on supplied black RG-6 coax cable to the power injector jack marked "PWR IN". Connect the other "F" connector on supplied RG-6 coax cable to jack on supplied AC wall transformer. See Figure 2. You can use a longer piece of RG6/U coax cable if required up to 100 feet between the AC adaptor and power insertor if required.

**STEP 7.** Mount the power injector to the wall using supplied screws. Plug in AC wall transformer to household wall outlet.

Figure 3

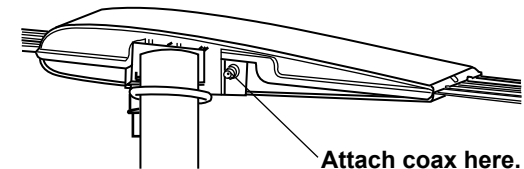

#### TIPS:

If splitting the signal to multiple TVs or combining with another signal source, it is strongly recommended that the power injector be installed between the antenna and the splitter/combiner input. In this case, the cable connection from the "TV" jack of the power injector goes to the splitter input or valid combiner input. Use splitters rated from 54-806 MHz or wider bandwidth (commonly 5-1000 MHz) for over-the-air television signal distribution.

Additional distribution/inline amplifiers must be installed FOLLOWING the TV output of the power injector, NOT on the download cable line connecting to the ANTENNA port. Check TV picture quality, if the power injector LED is glowing when powered, and antenna alignment prior to adding additional line amplifiers.

A maximum antenna-to-power injector length of 150 feet RG-6 or 150 feet RG-59 is acceptable.